

INSTRUCTIONS

910-31919
910-31924

PARTS:

- 2- Rotors
- 2 - Caliper brackets
- 6 - 3/8"-24 x 1 3/4" grade 8 bolts
- 6 - Flat washers

NOTES:

Read these instructions completely before attempting this conversion.

Make sure this kit fits your application before painting or plating. Parts that have been painted, plated or modified may not be returned.

THE FOLLOWING CALIPERS CAN BE USED WITH CONVERSION KIT:

- 1980-85 Cadillac Seville Rear Caliper w/Emergency Brakes
- 1978-83 Chevelle, Monte Carlo, Malibu, etc. Front Calipers

INSTRUCTIONS:

1. Remove the axles to take the backing plates off.
2. Install the caliper brackets with the caliper opening pointing up and towards the rear. On some models the shoulder on the brackets will point toward the outside of the car. Torque mounting bolts to 50 ft. lbs. dry or 35 ft. lbs lubed.
3. Install the axle grease seals, followed by the axles. It is recommended that new seals be installed.
4. Install rotors. In some cases the axle flange may need to be turned for the rotor to fit over it. This can be done with a conventional hand grinder or by taking it to a machine shop and having it put on a lathe. Once this is done, make sure that both mounting surfaces are clean with no debris that would make the rotor wobble. Hold in place with wheel nuts.
5. Check the brackets to make sure they are parallel with the rotors. Shim or grind the sleeves on the brackets as needed. Install calipers with bleeders pointing up.
6. Install brake hose. Double check all parts for interference and bolts for tightness.
7. Proceed to bleed brake system.

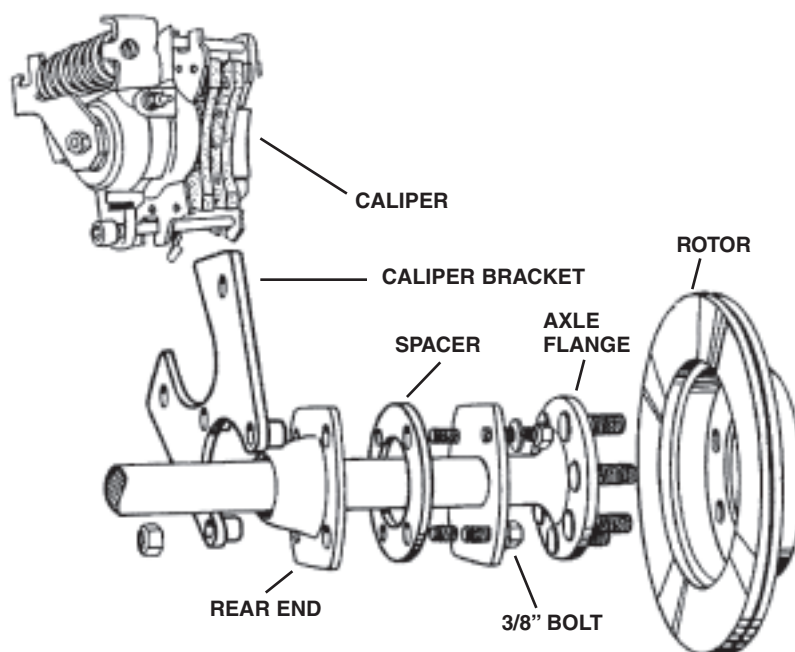

Speedway Motors Inc., P.O. Box 81906
Lincoln, NE 68501 (402) 323-3200
www.speedwaymotors.com

SPEEDWAY MOTORS
©2006

ADJUSTING AND BLEEDING EMERGENCY BRAKE CALIPERS

910-31946

1. When you install the calipers, put them in the position you like. One where the cable will work well (if you have the park brake calipers) and the hose connection is in a good location. If you go off road you can mount the calipers high to avoid brush and rocks. Don't worry about being in the right position to bleed the brakes. The calipers have to be taken off of the brackets to bleed anyway and once they are bled it does not matter what position they are in.
2. Once everything is installed and before you put the wheels on, bleed the calipers. Air rises so the bleed screw must be at the top. You can start by the normal bleeding methods, but the brakes will not work properly and you will have a soft pedal if you do not take the calipers off of the brackets and gravity bleed them to get the last of the air out.
3. To gravity bleed take the cover off of the master cylinder, take the calipers off of the brackets and hold behind the axle. Hold the caliper so that the bleed screw points forward, horizontal with the ground on the (small) 5^{1/2} inch pin to pin calipers and straight up on the (large) 7 inch pin to pin calipers. The mounting holes in the ears are around 45° on a non parking brake caliper and straight up one hole above the other on a parking brake caliper. Open the bleed screw and the fluid will start to dribble out. Slowly move the calipers just in case you are not in the correct position and also tap on the calipers with a rubber hammer to knock bubbles loose. Once the fluid is clear with no air bubbles, close the bleeder and hang that caliper on a wire and do the other side. Do both calipers again and then reinstall. (Do not step on the hydraulic pedal yet.) Go to step 5 for non-parking brake calipers.
4. Adjust the parking brake levers by pushing them forward. Each time you push them they should move off of the stop 3/8 to 1/2 inch. When released, they should always return to the stop. If they will not adjust, try putting a lever between the rotor and the pad and putting pressure on the piston, Now push the lever releasing pressure on the pad as the caliper adjusts. These are the only two ways we know of to adjust the parking brake. If the calipers won't adjust, you will have a low pedal because the piston will retract too far and will use up all your hydraulic pedal travel to put the brakes on. Once the parking brake calipers are adjusted, put a c-clamp on between the lever and the bracket to hold the parking brakes locked up.

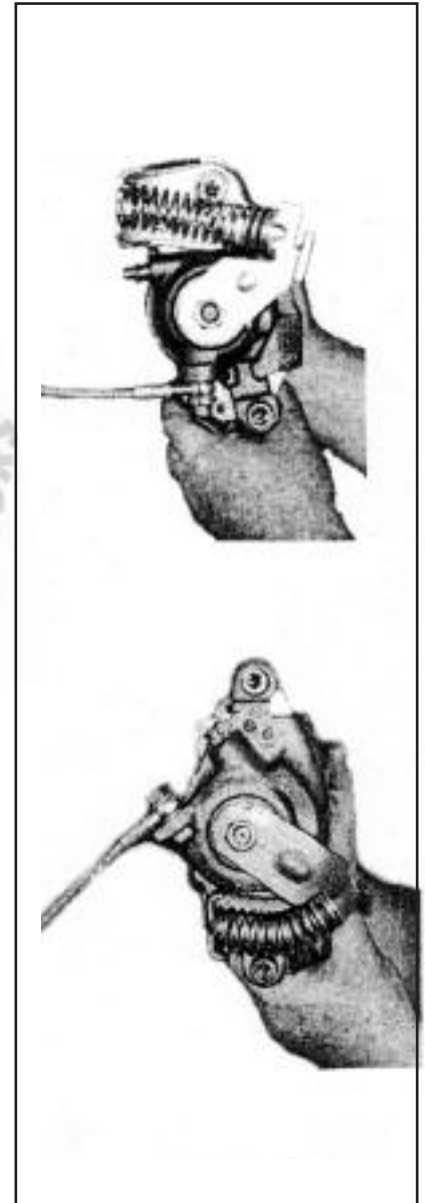

IMPORTANT

5. Step on the hydraulic pedal. It should be high and hard. If it is low and spongy or it will pump up, you still have air. Take the caliper off the brackets and bleed some more. If you have parking brake calipers and they are locked up against the rotors and there is no air in the rear system, then there will be no fluid movement in the rear brake system and the pedal should be as high as before you changed the brakes and had the parking brake on. It does not matter what size master cylinder you have. If there is no fluid movement you will have a high and hard hydraulic pedal. There might be a problem with your front system since you have a dual braking system. But if you have not changed the front, your pedal should be high and hard. It is not as easy to check if you are using non-parking brake calipers. The calipers run close to the rotors so check to see that the pads won't rattle. If your pedal is low and spongy, you have air. Take the calipers off and bleed them some more

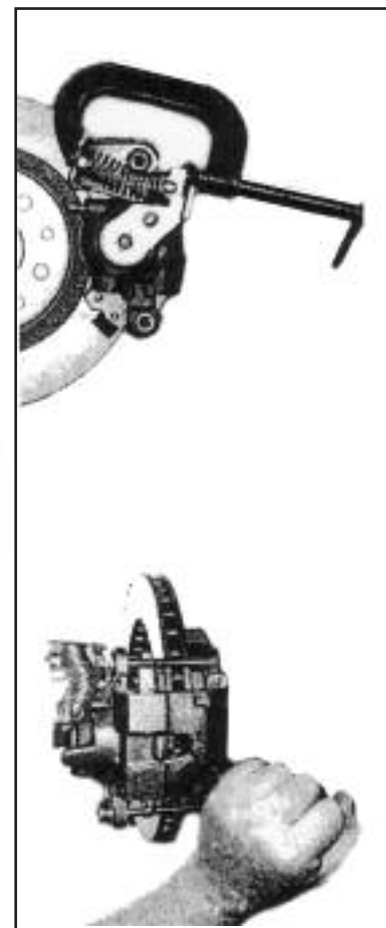

DISCLAIMER In an effort to offer our customers the low prices, quick service and great value, Speedway Motors reserves the right to change suppliers, specifications, colors, prices, materials. Each of the previous items is subject to change without notice. Speedway is not responsible for any typographical errors or misinterpretations. Quantities are limited on some items.

WARRANTY DISCLAIMER The purchaser understands and recognizes that racing parts, specialized street rod equipment, and all parts and services sold by Speedway Motors, Inc. are exposed to many and varied conditions due to the manner in which they are installed and used. Speedway Motors, Inc. makes no warranties, either express or implied, including any warranty of merchantability or fitness for a particular purpose other than those contained in its current catalog with respect to the goods identified on the face of the invoice. There is no warranty expressed or implied as to whether the goods sold hereby will protect purchaser or ultimate user of such goods from injury or death. Speedway Motors assumes no liability after this period.

DAMAGE CLAIMS Always inspect your package upon delivery. Inspect all packages in the presence of the delivery driver. The driver must note any damage. Ask the driver the Carrier's procedures for handling damage claims. You must hold the original box, packing material and damaged merchandise for inspection or the carrier will not honor the claim. Notify Speedway Motors customer service department for instructions on returning damaged goods. Speedway is not responsible if no notification is given within 5 days of receipt.

SHORTAGES Always check the contents of your delivery to insure all the parts that you ordered were received. Please read the invoice. Double check all packing materials, small items may be wrapped inside with these products. Shortages may occur from damage to the box, so save all packing materials. Inspect the box for holes that would allow parts to fall out. If you are missing any item(s) be sure to check your invoice for back orders or canceled items before calling the customer service department. If Speedway has to split a shipment into multiple boxes, packages may be delivered on different days. You need to contact the customer service department within 5 days of delivery to assure the prompt replacement. Speedway Motors assumes no liability after this period.

REFUSALS All refused COD customers will be billed a 15% restocking charge plus freight to and from the destination! If you have questions please contact Speedway's customer service department.

WARRANTY CLAIMS If an item has a manufacturer's warranty as being free from defects we will exchange only. If the item has been used and you are requesting warranty work, this may take up to 30 days as warranty work is done by the manufacturer NOT Speedway Motors. If you have any questions please contact customer service.

RETURNS Speedway wants you to be satisfied with your purchase. If within 30 days after you receive your shipment you are not satisfied, you may return the item for refund or exchange. All exchanged or returned merchandise must be in original factory condition with no modifications or alterations. Returned merchandise must include all packaging materials, warranty cards, manuals, and accessories. If the items being returned need to be repackaged there will be a re-packing charge. Repack the item in a sturdy box and include a copy of your invoice and complete the form on the back of the invoice. You must ship orders back **PRE-PAID. WE DO NOT ACCEPT COD SHIPMENTS.** All exchanges need to have reshipping charges included. Items that are returned after 30 days are subject to 15% restocking charges. All fiberglass returned will have 15% restocking charge. No returns on electrical parts, video tapes, and books. Absolutely no returns on special order or close out merchandise.

FREE CATALOGS Speedway Motors offers FREE catalogs for Race, Street, Sprint and Midget, Sport Compact and Pedal Car restoration.

****Some items are not legal for sale or use in California on pollution controlled motor vehicles. These items are legal in California for racing vehicles only which may never be used upon a highway.**



Speedway Motors Inc., P.O. Box 81906
Lincoln, NE 68501 (402) 323-3200
www.speedwaymotors.com