

McCULLOCH

SUPERCHARGER

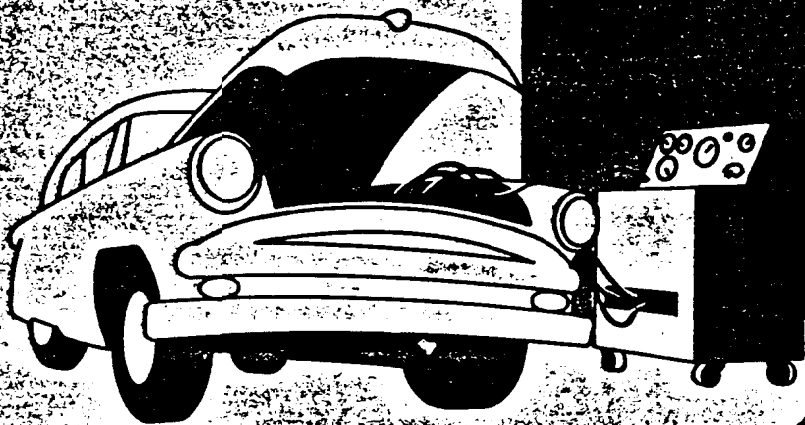

**INSTALLATION
AND
OPERATION
TROUBLESHOOTING**



PAXTON PRODUCTS

Division of McCulloch Motors Corporation

827 WEST OLIVE STREET - INGLEWOOD, CALIF.

TROUBLE SHOOTING AND SERVICE

INTRODUCTION

The **McCulloch** Supercharger, **Model VS-57** (-A, -B, -C) is a single stage, **centrifugal**-type supercharger designed for use with automotive, stationary, or marine internal combustion engines. Drive take-off is from the engine crankshaft through a single, cog-type vee belt. A variable-ratio input pulley on the supercharger provides for both a “**low blower**” and “**high blower**” range of operation. Normally, when the engine is cruising (operating under minimum load requirements), the supercharger is being driven in the “**low blower**” range. When demand is made for power, the supercharger control system causes the pulley to be shifted into the “**high blower**” range.

The lubrication system is completely self-contained, eliminating connections to the engine lubricating system. An internal oil sump holds eight ounces of lubricant, Type “**A**” automatic transmission fluid (AQ-ATF quality). A piston-type oil pump, actuated by a cam ground into the input shaft, provides pressure lubrication of the internal moving parts. A dip-stick **oil** gauge inserts in the oil filler tube located in the bearing housing of the supercharger.

A planetary drive system, incorporated between the input and output shafts, serves as a speed increaser for the impeller. As the system is a ball bearing, friction-type, the use of noise producing gears is eliminated. Spring-loaded **ball** races serve to automatically take up any wear that might develop in the system.

The Model VS-57 supercharger has been designed for installation before the carburetor in the overall carburetion system. Under no circumstances should the supercharger be installed between the carburetor and the *intake* manifold.

McCULLOCH MOTORS CORPORATION

6101 West Century Boulevard

Los Angeles 45, California

MECHANICAL OPERATION

1. GENERAL

As with all centrifugal-type **superchargers**, it is necessary to drive the impeller at a very high rpm rate to obtain boost pressure output. This is accomplished in the **McCulloch** Supercharger, Model VS-57 (-A, -B, -C), by incorporating two speed increasers in the drive system. The first increaser is the variable-ratio input pulley, which is keyed to the input shaft. The second increaser, which operates at a constant rate, is the planetary drive system between the input and output shafts.

When a 7-1/2 inch diameter crankshaft **pulley** is used, the variable-ratio pulley offers a 1.3 : 1 rpm increase in the fully closed position. When the pulley is fully opened, the rpm increase is 2.3 : 1. When the pulley flanges are fully closed, the supercharger is operating in the “**low** blower” range. When the flanges **are** fully separated, the supercharger is being driven in “**high** blower” range and maximum boost pressure output is being produced.

The variable-ratio action of the input pulley is accomplished by the use of a sliding, rear pulley flange. -(The front pulley flange is keyed to the input shaft through a splined hub.) The rear flange is fitted with a splined bushing, that rides the input shaft splined hub, and is coupled to its actuating air piston through a thrust-type ball bearing. Movement (or shifting) of the rear flange is automatically controlled by the supercharger control system.

The control system serves to both initiate the shifting cycle and regulate the boost pressure output of the supercharger. The main component of the system is the solenoid regulator, located in the bearing housing of the supercharger. The regulator is a solenoid operated valve that controls the passage of boost pressure, taken **from the** discharge throat of the carburetor, into an air chamber. Within the chamber is an air piston which is coupled to the rear, or sliding flange of the supercharger input pulley.

The solenoid can be energized in one of **several** ways. For full automatic operation of the supercharger, it is recommended that a vacuum switch be used to **close the** solenoid regulator circuit. (A vacuum switch is one in which the opening and closing of the contact points is controlled by the degree of vacuum present in the engine intake manifold.)

II. DRIVE SYSTEM

The drive system of the McCulloch Supercharger, Model VS-57, as shown in Figure 1, is composed of the following component assemblies:

- a. Variable-ratio input pulley
- b. Input Shaft
- c. Planetary drive system
- d. Output shaft.

The fixed flange (A-1) of the variable-ratio input pulley (A) is keyed to the input shaft (B) through a splined hub. The sliding flange (A-2) of the pulley is fitted with a splined bushing to permit constant drive of the input shaft through the full limit of travel of the flange. Movement of the flange is controlled by an air piston (ref.) working in an air chamber, or cylinder. The pulley is shown in its maximum ratio position.

The ball driver, (C) assembled to the input shaft, serves to rotate the drive balls (D) of the planetary system around the inner faces of the outer ball-races (E). The clutch discs (F) prevent the outer ball-races from turning in their respective seats. --

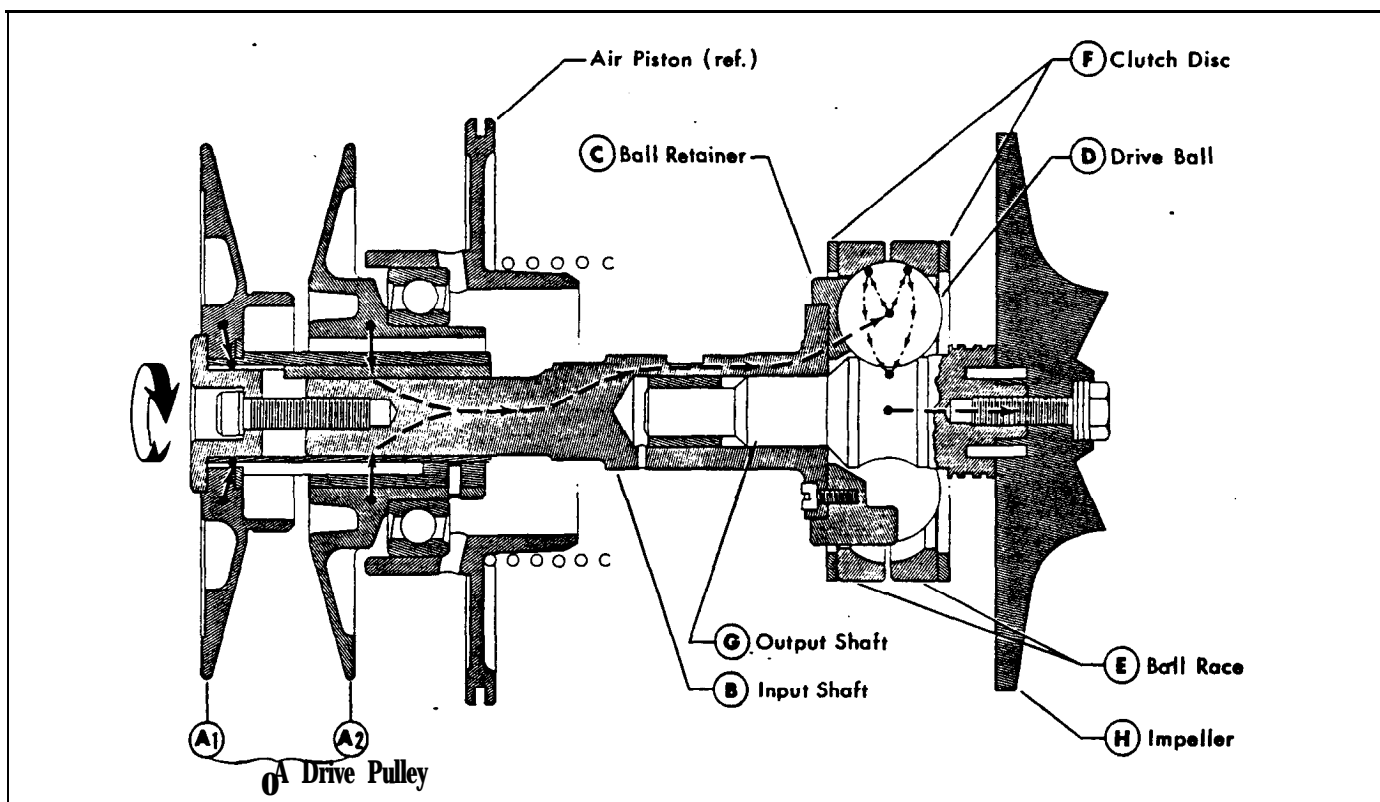

Figure 1

As the drive balls (D) revolve around the fixed cage formed by the two outer races, (E), they also rotate around their individual axis, as shown in Figure 2. This latter motion is transmitted directly to the output shaft, (G), causing it to rotate. As the output shaft serves as the inner race of the planetary system, the system ratio, 1 : 4.4, is calculated between the inner diameter of the ball races and the raceway of the output shaft.

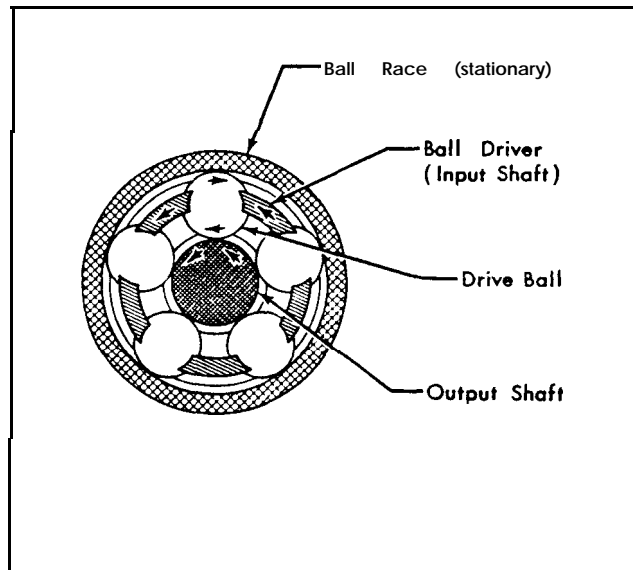

Figure 2

III. VARIABLE RATIO INPUT PULLEY

The variable ratio input pulley acts as a speed increaser (in shaft rpm) between the crankshaft pulley and the supercharger. Normally, during cruising operation (minimum load requirements), the pulley flanges will be closed and the drive belt will be at the extreme outside edge of the pulley.

Upon full throttle acceleration or demand for power, the pulley will open and the drive belt will move to the bottom of the pulley, thereby increasing the input shaft rpm.

Shifting of the variable ratio input pulley is a result of the combined functions of the control system, solenoid regulator and the belt-tensioning arm and idler pulley.

When the supercharger shifts from “high blower” to “low blower”; it is a result of boost pressure (taken from the supercharger discharge throat) being passed into the air chamber, behind the air piston. The pressure drives the piston forward and the movement is transmitted to the sliding flange of the pulley assembly through a thrust-type ball bearing. The pressure is sufficient to overcome the tension applied to the drive belt by the belt-tensioning arm and, as the pulley flanges close, the belt is forced to the top of the pulley. An equalizer spring behind the piston helps to overcome the effect of the tensioning arm against the drive belt.

NOTE

During idle speed engine operation, the drive belt and variable-ratio pulley are in the "high blower" position. This is because the developed boost pressure is insufficient to override the tension exerted against the drive belt by the belt-tensioning arm.

During the shift cycle from "low blower" to "high blower", a valve in the control system closes to prevent boost pressure from entering the air chamber. The pressure within the chamber bleeds off and the tension on the drive belt (exerted by the belt-tensioning arm) causes the belt to pull down into the pulley and separate the two flanges.

The time required for either phase of the shifting cycle is approximately one second.

The belt-tensioning arm is generally mounted on the same bracket used to mount the supercharger. The spring-loaded arm is geometrically located with relation to the center line of the supercharger input shaft. The existing design should not be altered in any way as such alteration will affect the shifting cycle of the variable -ratio pulley.

IV. CONTROL SYSTEM

The control system of the Model VS-57 supercharger serves to both initiate the shifting cycles of the unit and to regulate the boost output pressure. This is accomplished by controlling the movement of the sliding flange of the input pulley to either increase or decrease the effective working diameter of the pulley. The design makes possible three phases of supercharger operation, as follows:

Phase A - Cruise Range, or Low Blower

Phase B - Power Demand, or High Blower

Phase C - Regulation (regulated high blower)

In effect, the control system is an electrically operated valve which controls the passage of boost pressure from the discharge throat into the **air** chamber.

The main electrical component of the system is the solenoid regulator, which is energized by the closing of an external switch. Located in the bearing housing, the regulator intersects an air passageway leading between the discharge throat and the air chamber containing the air piston. The external switch can be either a vacuum switch, operated off the intake manifold; or a kick-down type switch operated by depressing the accelerator pedal.

The three phases of supercharger operation, as shown in Figure 3, are:

Phase A

The solenoid regulator is not energized and the valve is open, permitting boost pressure to enter the air chamber. The air piston is driven forward, closing the **variable-ratio** pulley, and the supercharger is operating in “**low blower**”. Minimum horsepower is required to drive the supercharger during this phase, as the supercharger is not producing high level output. This phase extends across the cruising range of the engine, where the engine does not demand, and cannot use, boost pressure. Upon acceleration, or full load engine demand, the supercharger shifts into Phase B operation.

NOTE

When the solenoid is energized by means of an external vacuum switch, Phase B operation is initiated when the intake manifold vacuum rises to zero.

Phase B

As soon as the solenoid regulator is **energized**, the armature **lifts and** seals against the valve stem to block the passage of boost pressure into the air chamber. When the source of constant pressure is removed from behind the air piston, the pressure that exists in the chamber bleeds off. The tension exerted against the drive belt by the belt-tensioning arm causes the belt to pull down into the variable-ratio pulley. As the sliding flange moves backward, driving the air piston back into the air chamber, the effective **working** diameter of the pulley is reduced and the rpm speed of the input shaft is increased. The supercharger is now in the “**high blower**” range of operation and the boost pressure output, in psi, is increased.

As the engine speed increases under full throttle, the boost pressure output also continues to increase until it reaches a predetermined level, based upon the setting of the solenoid regulator. At this point, the solenoid regulator enters Phase C operation to regulate the output of the supercharger.

Phase C

The design of the supercharger and drive system is such that maximum boost pressure output is produced at a crankshaft **speed** below maximum engine rpm.

This permits production of usable boost pressure. at lower engine speeds and also increases the range of engine speeds over which usable boost pressure is produced. However, if maximum output is produced at a mid-range speed of the engine, it is obvious that pressure output would continue to increase as the engine speed increases to maximum rpm. Therefore, it is necessary to regulate the pressure output, in psi, to a level that is compatible with engine design and available fuel.

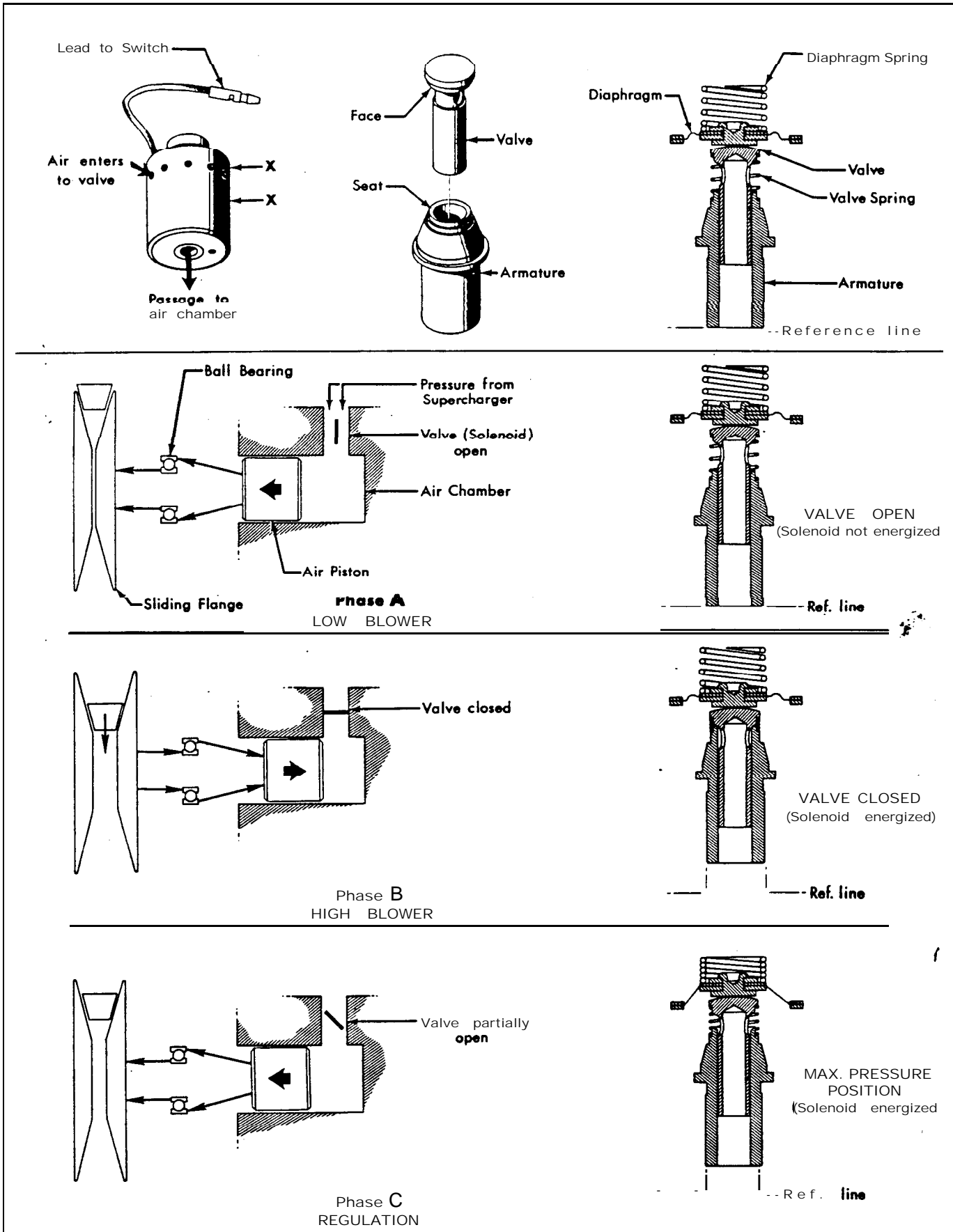

Figure 3

This is accomplished by the inclusion of a spring loaded diaphragm within the case of the solenoid regulator. A spring on the top side of the diaphragm is adjustable (by means of an adjusting screw) and the change of spring rate determines the pressure, in psi, required to distend and lift the diaphragm. As the diaphragm is positioned against the head of the valve, any upward movement permits the valve to lift off the seat formed by the armature. It is this function that comprises the Phase C operation of the solenoid regulator. The mechanical operation is as follows.

During “high blower” operation, the **solenoid** is energized and the armature has moved upward to seal off the passage of boost pressure into the air chamber. As the engine speed continues to increase and the boost pressure output reaches the level for which the diaphragm spring has been preset, (for example: 4 psi) any pressure gain over four pounds will cause the diaphragm to distend. This permits the valve to lift off the seat to a like degree, thus opening the passageway to the air chamber. As the equalizing spring behind the air piston is in a compressed state, neutralizing the tension exerted against the drive belt by the belt-tensioning arm, the small amount of pressure passing the partially opened valve is sufficient to cause the air piston to move forward. This action, in turn, causes the sliding flange of the variable-ratio pulley to move forward and the effective working diameter of the **pulley** is reduced. As the pulley ratio changes, the rpm of the input shaft is reduced and boost pressure output is also reduced to the regulated level.

This regulating action continues through the high end of the engine speed (in rpm) curve until the full limitation of the diaphragm has been reached. However, the overall design of the supercharger and control system is such that the limit of regulation holds very closely to the maximum usable engine rpm.

V. LUBRICATION

The supercharger Model VS-57 (-A, -B, -C) is lubricated through the utilization of an internal, piston-type oil pump working off a cam ground into the input shaft. The oil sump holds eight ounces of lubricant, and changing of the lubricant is not required except under extreme conditions of operation.

WARNING

The supercharger lubrication system is designed to use only Type A automatic transmission fluid (AQ-ATF quality). Under no circumstances **should** any tier, type of lubricant be used or added to the oil sump. This warning includes the use of **friction-reducing compounds or fluids, and their use will void** the supercharger warranty.

A dip-stick type oil gauge, inserted in the oil filler tube located in the bearing housing, indicates the level, and safe operating range of the lubricant in the sump. The supercharger should never be operated with the dip-stick removed from the filler tube as loss of lubricant will result.

The oil level within the supercharger should be checked each time the engine oil is checked. Under normal operation it should not be necessary to add lubricant to the sump between intervals of 1500 to 2000 miles of operation.

WARNING

Should excessive oil consumption occur, the supercharger should be taken to an authorized McCulloch Supercharger Dealer for checking. If this is not convenient, it is recommended the supercharger drive belt be removed and the supercharger not operated until such time that a thorough check can be made.

Under normal operation, the lubricant within the supercharger should retain its original color without darkening or formation of sludge. Therefore, when checking lubricant level, wipe the dip-stick with either a clean cloth or paper and check for condition of lubricant. Extreme darkening or the presence of foreign matter in the lubricant is sufficient cause for draining and thoroughflushing of the lubricant sump. After flushing, refill the sump with eight ounces of Type A automatic transmission fluid (AQ-ATF quality).

NOTE

It is recommended the supercharger be taken to an authorized **McCulloch** Supercharger Dealer for servicing when flushing of the internal lubricant sump is indicated.

CHECK OUT PROCEDURES FOLLOWING INSTALLATION

After the supercharger has been installed, the over-all system must be checked out for correct functioning if engine performance benefits are to be realized. The check out procedure is simple and, if followed, will assure the system is functioning correctly.

When checking the supercharger boost pressure a 0 - 10 psi (minimum scale) pressure gage must be used.

NOTE

A combination vacuum - pressure gauge, suitable for installation in the driver compartment of the automobile, is available from your **McCulloch** Supercharger Dealer. Once installed, the gauge will provide means of constantly **checking** supercharger and engine performance.

The following list briefly describes the function of each major component of the installation.

SUPERCHARGER - A centrifugal-type air pump designed to provide usable boost pressure to the **carburetion** system at all engine speeds in excess of 1500 rpm, as required.

SOLENOID REGULATOR - A solenoid operated valve, located in the bearing housing of the supercharger, that controls the flow of boost pressure into the air chamber of the supercharger. The solenoid regulator also serves to regulate maximum boost pressure output of the supercharger.

VACUUM SWITCH (or THROTTLE KICK-DOWN SWITCH) - A single pole switch used to either open or close the solenoid regulator circuit.

When a throttle kick-down switch is used, it is generally **linked** to the foot accelerator to close at approximately 75% of full throttle.

BELT TENSIONING ARM - A functional component of the installation, designed and geometrically installed as a source of opposing force in the supercharger belt drive system. Free movement of the arm on its pivot shaft is essential for a good shifting pattern.

VACUUM ADVANCE UNIT - This special unit replaces the stock vacuum advance unit on car engines utilizing the vacuum advance principle of spark control. It differs from the stock unit only in that a pressure nipple is installed in the case to provide a means of pressurizing the back side of the diaphragm.

ELECTRICAL FUEL PUMP - Installed at the fuel tank end of the fuel line, the electric fuel pump is energized only when the solenoid regulator is energized. In operation, the electric fuel pump provides an adequate flow of fuel to the mechanical fuel pump and carburetor when the supercharger is operating in the "high blower" range.

NOTE

Fuel pressure, measured at the carburetor, should always be two pounds greater (minimum) than the supercharger boost pressure (measured at the supercharger discharge throat).

Failure or malfunction of any one of the system components will result in unsatisfactory engine performance relative to the supercharger installation.

CHECK OUT PROCEDURES

After the supercharger has been installed, a complete check should be made to insure correct functioning of all components. The following check list fully covers all procedures for such checking.

1. Turn on ignition switch but do not start engine.
2. Using a short length of wire as a jumper, short the two terminals of the vacuum switch (or kick-down switch). A sharp click should be heard as the solenoid regulator valve closes.

Also, as the electric fuel pump is now energized, a whirring sound should be heard at the rear of the car. Repeat the test several times, making sure the solenoid valve closes and the electric fuel pump starts each time.

NOTE

Should the solenoid regulator and electric fuel pump be energized when the ignition switch **is turned** on and before the terminals of the vacuum switch are shorted out, it indicates the diaphragm in the vacuum switch was **left in** the closed position following testing. This is not serious as the diaphragm will open the switch contacts as soon as the engine is started. However, to prevent possible carburetor flooding, do not leave the ignition switch on for too long a period before starting engine.

3. Check the fuel line from **tank** to engine to be sure all fittings are secure and are not leaking under pressure.
4. Start and warm up the car engine.

5. Advance throttle until engine is turning approximately 1500 rpm. The rear flange of the supercharger input pulley should start closing to the front flange, moving the drive belt to the outer edge of the pulley sheave. (At idle engine speed, the flanges of the input pulley are separated and the drive belt is riding at the bottom of the pulley.)

WARNING

Avoid overspeeding of the engine under no-load conditions, as such operation can result in engine failure with or without a supercharger.

6. Advance **throttle** until engine is turning approximately **1500** rpm, and short out terminals of vacuum (or kick-down) switch with jumper wire. The rear flange of the supercharger input pulley should move away from the front flange and the drive belt should drop to the bottom of the pulley.
7. (Vacuum switch installations only.)
Remove hose from fitting at bottom of vacuum switch and plug free end of hose. After attaching a long length of hose to the vacuum switch fitting, advance the engine speed to approximately 1500 rpm. Blowing into the hose will cause the vacuum switch contacts to close and the supercharger input pulley should function as described in Step 6. Sucking on the hose will open the vacuum switch contacts and the pulley should start to close, with the drive belt moving to the outside edge of the pulley. After testing, reconnect the manifold hose to the vacuum switch.
8. If car engine is equipped with vacuum-type spark advance control check the functioning of the special vacuum advance unit, using a standard timing light. With the vacuum line to the distributor disconnected, there should be no **fluctuation** of the timing pip when the engine is accelerated.

Reconnect the vacuum line and again check with the timing light. The timing pip should now indicate advance and retard action as the engine is accelerated. Do not alter the basic distributor setting at this time.

CHECKING SUPERCHARGER AND FUEL PRESSURES

To insure **maximum performance** (and also check the setting of the solenoid regulator) it is necessary to measure the discharge pressure of the supercharger, and the fuel pressure at the carburetor. These measurements require the utilization of two, 0 - 10 psi gauges; one connected at the supercharger discharge throat, and the second connected in the fuel line at the carburetor. Figure 4 shows the suggested method of connecting the two gauges in the system. So connected, one gauge will indicate the output pressure of the supercharger, while the second gauge **will indicate** fuel pressure.

As the checks require engine speeds in excess of 2900 rpm under load, the car must either be road or dynamometer tested.

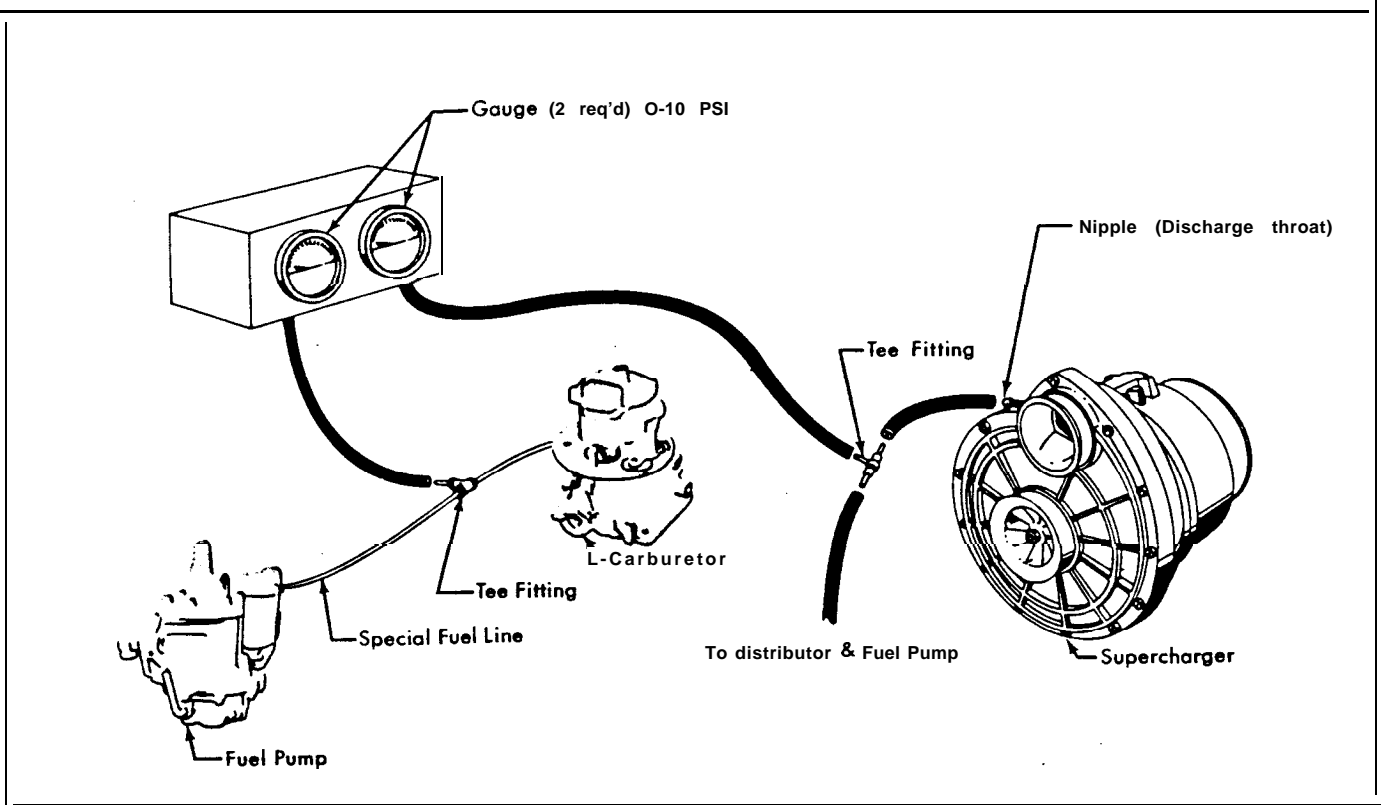

Figure 4

WARNING

Do not attempt to make the following checks by “no load” engine operation. To do so can, and possibly will, cause severe engine damage.

1. Attach pressure gauges as shown in Figure 4, with instruments in driver compartment. Use care not to crush the hose leads when closing hood.
2. Road test the car, using full throttle. Under sustained running, with the engine turning in excess of 2900 rpm, the supercharger discharge pressure should indicate 5 psi maximum.

When making the road test, full throttle must be used if a vacuum switch is used to close the solenoid regulator circuit. At less than full throttle there is sufficient vacuum in the intake manifold to hold the vacuum switch open and the supercharger will not be caused to shift into “high blower”.

During the test, as road speed and engine rpm increase, the maximum indicated supercharger discharge pressure (which should not exceed 5 psi) should remain constant.

NOTE

If a **McCulloch** Pressure - Vacuum Gauge was installed and connected to the intake manifold, it will **indicate** approximately one pound less than does the instrument connected to the supercharger. This is normal as there is a pressure drop across the carburetor.

3. At the same time the supercharger discharge pressure is being checked, fuel pressure at the carburetor should be checked. Provided the electric fuel pump has been correctly wired into the supercharger control system, the pump will be energized at the same time the supercharger is shifted to "**high blower**". At the instant of shifting (electrical circuits energized) the fuel pressure should start to increase from a normal 2 to 3 psi reading. The fuel pressure should then increase until it reaches a pressure higher than the indicated supercharger discharge pressure.

SOLENOID REGULATOR

The solenoid regulator is accessible by removing the medallion from the bearing housing of the supercharger.

CAUTION

Do not misplace the small coil-spring that will be freed when the medallion is removed. As the spring serves to both retain the regulator and ground it, do not fail to replace the spring when reassembling the medallion to the bearing housing.

ADJUSTMENT OF SOLENOID REGULATOR

If previous testing indicates that only adjustment of the regulator is required, it is not necessary to remove the regulator from the supercharger. After removing the medallion, carefully dig out the sealing compound from the top, center hole of the regulator. A **5/64** inch Allen wrench can then be used to turn the adjusting screw.

Turning the screw in (clockwise) **will increase the** spring pressure on the diaphragm and a higher level of discharge pressure, in psi, will be required before regulation becomes effective.

WARNING

Do not exceed a setting that results in a discharge pressure greater than 5 psi at the supercharger discharge throat, as material damage may result.

When the screw is backed out (counter-clockwise) spring tension on the diaphragm is relieved, and a lesser discharge pressure will initiate regulation.

CAUTION

After adjusting the regulator and before testing, both the spring and medallion must be replaced. **If** the spring is not replaced the regulator will fail to function as the ground circuit is incomplete. Failure to replace the medallion can result in the regulator being blown from its well in the bearing housing, as the medallion also serves as a retainer.

Road test the car under full throttle operation to obtain a maximum discharge pressure reading. Either a too high or a too low pressure reading should be corrected by resetting the adjusting screw. When the correct adjustment has been determined, use sealing compound to hold the adjusting screw at the correct setting.

REMOVAL OF SOLENOID REGULATOR

When necessary, the solenoid regulator can be easily removed from the supercharger without use of special tools. After removing the medallion and retaining spring, disconnect the regulator electrical lead at the bullet connector. Grasp the solid, upper portion of the regulator with pliers and work back and forth while pulling straight up and the regulator will be freed.

As the regulator cannot be repaired, defective regulator must be replaced with a new unit. Before installing a regulator, pull the **“O” rings** from the well and check for Cuts. If necessary; replace the **“O” rings** to prevent blow-by and leakage.

To replace regulator and **“O” rings**, first, lightly oil the rings before positioning in the upper and lower grooves of the **well**. The solenoid should then be pushed into place, making certain it bottoms in the well. Reassemble electrical connector, spring, and medallion.

NOTE

Always test the **supercharger** for discharge pressure after replacing the solenoid regulator. **If** necessary, readjust the regulator as outlined.

TROUBLE SHOOTING

For maximum gained performance after installation of the supercharger, the engine should be in top mechanical condition. As the mechanical condition of the engine is the responsibility of the individual, such condition cannot be covered in this manual. However, it must be pointed out that engine deficiencies, normally unnoticed before supercharging, will possibly be aggravated by operation of the supercharger. Because of this the supercharger will often be blamed for malfunctioning when such is not the case.

Therefore, in such instances the functioning of the supercharger and control system should be checked out for correct operation. If malfunctioning does exist, the source of trouble can be rapidly located through use of the following trouble shooting charts.

NOTE

The Trouble Shooting Chart covers only the possible sources of trouble that are directly traceable to the supercharger control system and component assemblies. Possible sources of mechanical malfunction of the supercharger are covered in a separate manual. Therefore, if malfunction continues after checking per the Trouble Shooting Chart, it can be assumed the trouble is of internal mechanical nature.'

TROUBLE SHOOTING - GENERAL

Maximum performance of the engine with supercharger installed depends upon the proper functioning of all system components. The following list of trouble symptoms can be used to rapidly determine sources of possible system failures. (See Diagram **A.**)

Supercharger does not shift

- A- Defective solenoid.
- B- Broken wire or poor connections.
- C- Defective vacuum switch.

Low fuel pressure.

- D- Electric fuel pump inoperative.
- E- Mechanical fuel pump defective.
- F- Restrictions in fuel line.
- G- Wrong float level in carburetor.
- H- Hose split or off fittings.

Flooding of engine.

- G- Float level set too high.
- G- Needle valve not seating.
- G- Loose jets or power valve.

Spark advance (vacuum type) inoperative.

- H- Hose split or off fittings.
- I- Slit diaphragm in vacuum advance unit.
- I- Arm binding.

Engine cuts out when **super-**charger shifts to "**high blower**".

Lead to vacuum switch attached to **sec-**ondary binding post instead of primary binding post.

Main lead wire from switch to coil too small for extra current demand of solenoid and electric fuel pump. (Replace **lead** with larger size wire to correct.)

Short in supercharger control system wiring.

Poor Engine Performance
(Surging or erratic)

Test Procedure
ROAD OR DYNAMOMETER TESTING REQUIRED

SUPERCHARGER BOOST PRESSURE TOO LOW (5* MAX AT DISCHARGE THROAT)

- SOLENOID OUT OF ADJUSTMENT. ADJUST TO 5* MAX. AT DISCHARGE THROAT.
- BOOST PRESSURE OKEH
- DEFECTIVE SOLENOID OR VACUUM SWITCH.
- BOOST PRESSURE OKEH

MECHANICAL MALFUNCTION OF SUPERCHARGER. PROCEED WITH TESTING AFTER REPAIR.

SUPERCHARGER BOOST PRESSURE OKEH

ROAD TEST

IGNITION

- ① TIMING
- ② POINTS
- ③ SPARK PLUGS

VACUUM SPARK ADVANCE

- ④ SPLIT HOSE
- ⑤ LEAKING DIAPHRAGM
- ⑥ ACTUATING ARM BINDING

CARBURETION

- ⑦ LOW FUEL PRESSURE
- ⑧ INCORRECT MAT LEVEL
- ⑨ JETS LOOSE OR WRONG SIZE
- *⑩ SECONDARY BUTTERFLY LINKAGE BINDING

DIAGRAM A

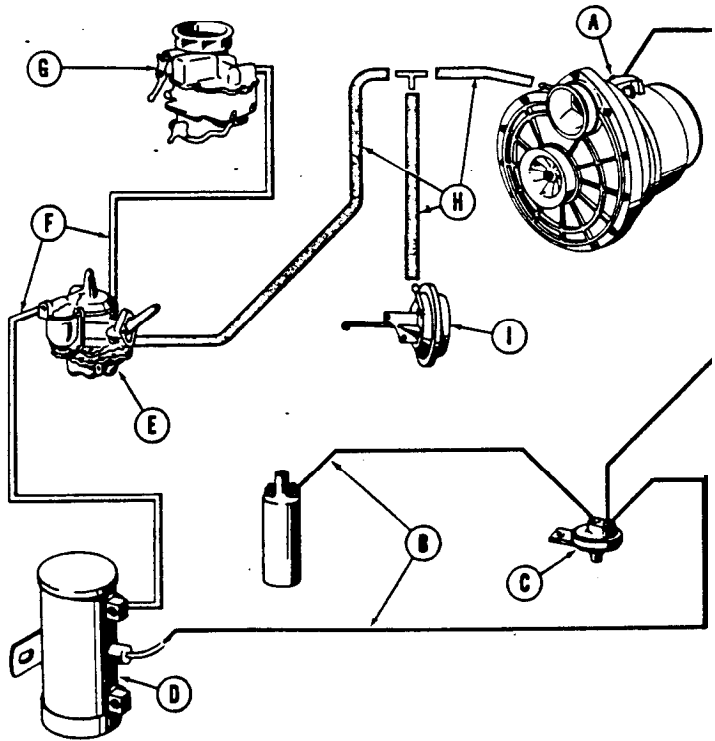

- 1 SET FOR MINIMUM DETONATION.
- 2 SET TO MANUFACTURER'S RECOMMENDATION.
- 3 AS RECOMMENDED
- 4 REPLACE HOSE.
- 5 REPLACE VACUUM ADVANCE UNIT.
- 6 DETERMINE CAUSE AND CORRECT.
- 7 2* HIGHER THAN SUPERCHARGER PRESSURE (MIN.)
- 8 SET TO MANUFACTURER'S RECOMMENDATION.
- 9 TIGHTEN OR REPLACE AS REQUIRED.
- 10 *VELOCITY CONTROLLED ONLY. CHECK AND CORRECT IF NECESSARY.

Supercharger fails to shift: Low to high ratio

Test Procedure
 START ENGINE AND SET AT 1500 RPM. DRIVE BELT SHOULD MOVE TO OUTER EDGE OF PULLEY.

SUPERCHARGER DOES NOT SHIFT: HIGH TO LOW

- VACUUM SWITCH SHORTED OUT - REPLACE
- HIGH TO LOW SHIFT OKEH
- CLEAN & OIL IDLER ARM BUSHING AND SHAFT
- HIGH TO LOW SHIFT OKEH

IF SUPERCHARGER STILL DOES NOT SHIFT CHECK FOR MECHANICAL MALFUNCTION. PROCEED WITH TESTING AFTER REPAIR.

TEST (BY SHORTING OUT VACUUM SWITCH)

LOW TO HIGH SHIFT OKEH

TEST VACUUM SWITCH
 REMOVE AND PLUG MANIFOLD HOSE. INSTALL LENGTH OF HOSE ON VACUUM SWITCH AND BLOW INTO HOSE TO CLOSE SWITCH.

DOES SHIFT

DOES NOT SHIFT

TROUBLE OVER

DOES SHIFT

○ GUMMY DRIVE BELT. CLEAN WITH ALCOHOL.

DOES NOT SHIFT

DOES SHIFT

○ CHECK FOR POOR CONNECTIONS OR BROKEN WIRES IN CIRCUIT.

DOES NOT SHIFT

DOES SHIFT

○ REPLACE SOLENOID

DOES NOT SHIFT

DOES SHIFT

○ CLEAN AND OIL IDLER BUSHING AND SHAFT.

DOES NOT SHIFT

DOES SHIFT

○ DEFECTIVE IDLER ARM SPRING CARTRIDGE

DOES NOT SHIFT

CHECK SUPERCHARGER FOR MECHANICAL MALFUNCTION. PROCEED WITH TESTING AFTER REPAIR.

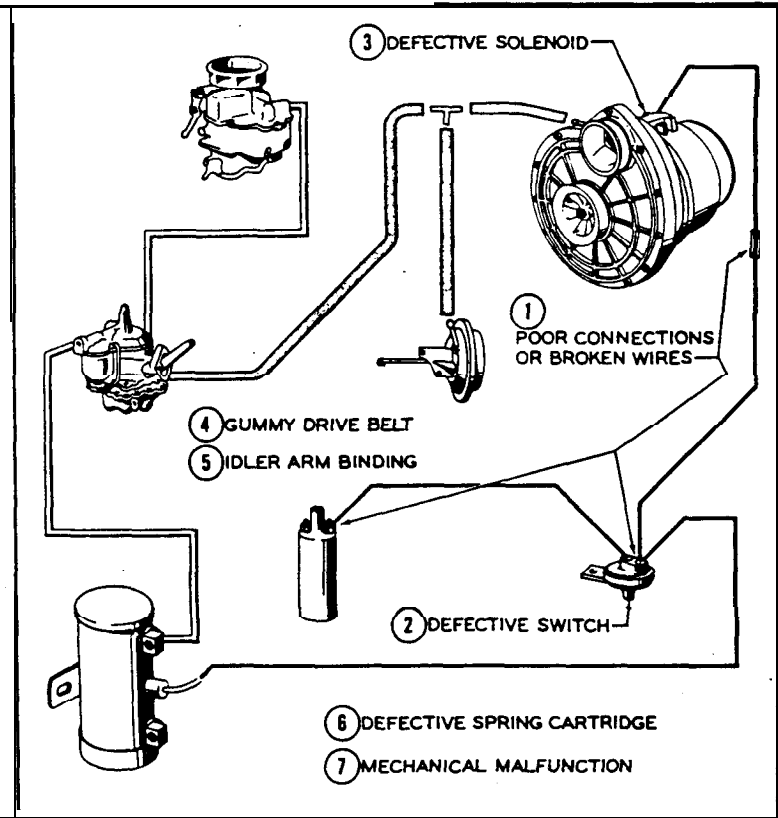

PARTS LIST

MCCULLOCH SUPERCHARGER MODEL VS - 57A

INDEX NO.	PART NO.	1	2	3	4	5	6	7	NOMENCLATURE	UNITS REQD.
	37000A	Supercharger Assembly								
1	101948	Screw, flat hd. mach. 10-24 x .875	2
2	37086A	Medallion	1
3	37149	Spring, retaining	1
4	101229	Grommet	1
5	37295	Solenoid Regulator Assembly	1
6	102462	"O" ring	2
7	37025	Oil Level Gauge Assembly	1
8	37027	Spring, oil level gauge	1
9	102225	"O" ring, oil level gauge	1
10	102549	Screw, socket hd. 5/16-24 x 1.25	1
11	102550	Lockwasher	1
12	37203	Retainer, driven pulley	1
13	37079B	Driven Pulley Assembly (fixed flange)	1
14	37080A	Hub, driven pulley	1
15	37204	Washer, driven pulley	1
16	37075A	Flange, fixed - driven pulley	1
17	37076A	Sliding Pulley Assembly	1
18	102373	Pin - .125" dia. x .34 lg.	3
19	37074A	Bushing, splined	1
20	102375	Ball bearing	1
21	37077	Flange, sliding - driven pulley	1
22	37081	Ring, retaining - air cylinder cover	2
23	37082	Cover, air cylinder	1
24	37078A	Air Cylinder Piston Assembly	1
25	37083	Ring, outer - air cylinder piston	1
26	37072A	Piston, air cylinder	1
27	37087	Spring, piston - air cylinder	1
28	102 134	Screw, fil hd. mach. 10-24 x .88	13
29	100436	Lockwasher - #10	1
30	100003	Washer - plain	13
	37129	Scroll Cover Assembly	1
31	102436	Hose connection	1
32	37023A	Cover, scroll	1
33	102199	Screw, hex hd. 5/16-24 x 1.25	1
-34	100271	Lockwasher 5/16 SAE med.	1
35	100350	Washer, retaining - impeller	1
36	37021	Impeller	1
37	37018	Shim (Dulite black) (.026 - .028)	As Req'd.
	37018A	Shim (Cadmium) (.030 - .032)	As Req'd.
	37018B	Shim (Blue) (.034 - .036)	As Req'd.
	37018C	Shim (Red) (.038 - .040)	As Req'd.
	37018D	Shim (Green) (.042 - .044)	As Req'd.
	370183	Shim (Brown) (.019 - .021)	As Req'd.
	37018F	Shim (Yellow) (.006 - .007)	As Req'd.

INDEX NO.	PART NO.	1	2	3	4	5	6	7	NOMENCLATURE	UNITS REQD.
38	100822	Screw, hex hd. 1/4-20 x 1.25	6
39	100246	Lockwasher 1/4 SAE med.	6
40	100005	Washer - plain 1/4 (AN960-416)	6
41	101254	"O" ring 6 1/2" I.D.	2
42	37090	Decal	1
	37056A	Bearing Housing Assembly	1
43	37084	Ring, inner - air cylinder	1
44	102430	Seal - input shaft	1
45	37024	Sleeve - oil level gauge	1
46	37085A	Housing, bearing	1
47	37073	Key, pulley hub	1
48	37094	Spacer, shaft seal	1
	37052A	Oil Pump and Input Shaft Assembly	1
49	102 197	Ball bearing (ND 3205-X1A)	1
	37054B	Oil Pump Assembly	1
50	37019	Retainer - oil pump screen	1
51	37026	Screen - oil pump	1
52	37197	Plug - oil pump	1
53	37015	Spring, plunger - oil pump	1
54	37007B	Plunger - oil pump	1
	37055B	Oil Pump Body Assembly	1
55	100549	Ball - 3/16" dia (Stainless Steel-Grade 1)	1
56	37006	Bushing	1
57	37309	Body, oil pump	1
58	102198	Ball bearing (ND 3206-X1A)	1
59	37012	Screw, input shaft	5
60	37011	Driver, ball (retainer)	1
	37053	Input Shaft Assembly	1
61	37010	Bushing, input shaft	1
62	37009	Shaft, input	1
63	37004A	Race Load Assembly	1
64	37064	Ring, snap	1
65	37062	Cage, spring - race load (rear)	1
66	37063A	Spring - race load	12
67	37061	Cage, spring - race load (front)	1
68	37088	Disc, clutch - ball race	2
69	37008	Race, ball	2
70	102 194	Ball, drive 1.0625" dia. - steel	5
71	37051A	Output Shaft Assembly	1
72	37206	Ring, labyrinth	2
73	37003A	Slinger, oil	1
74	101556	Pin, roll	2
75	37002A	Shaft, output	1
	37050A	Scroll Assembly	1
76	102 196	Pin, Dowel	2
77	37001A	Scroll, Supercharger	1

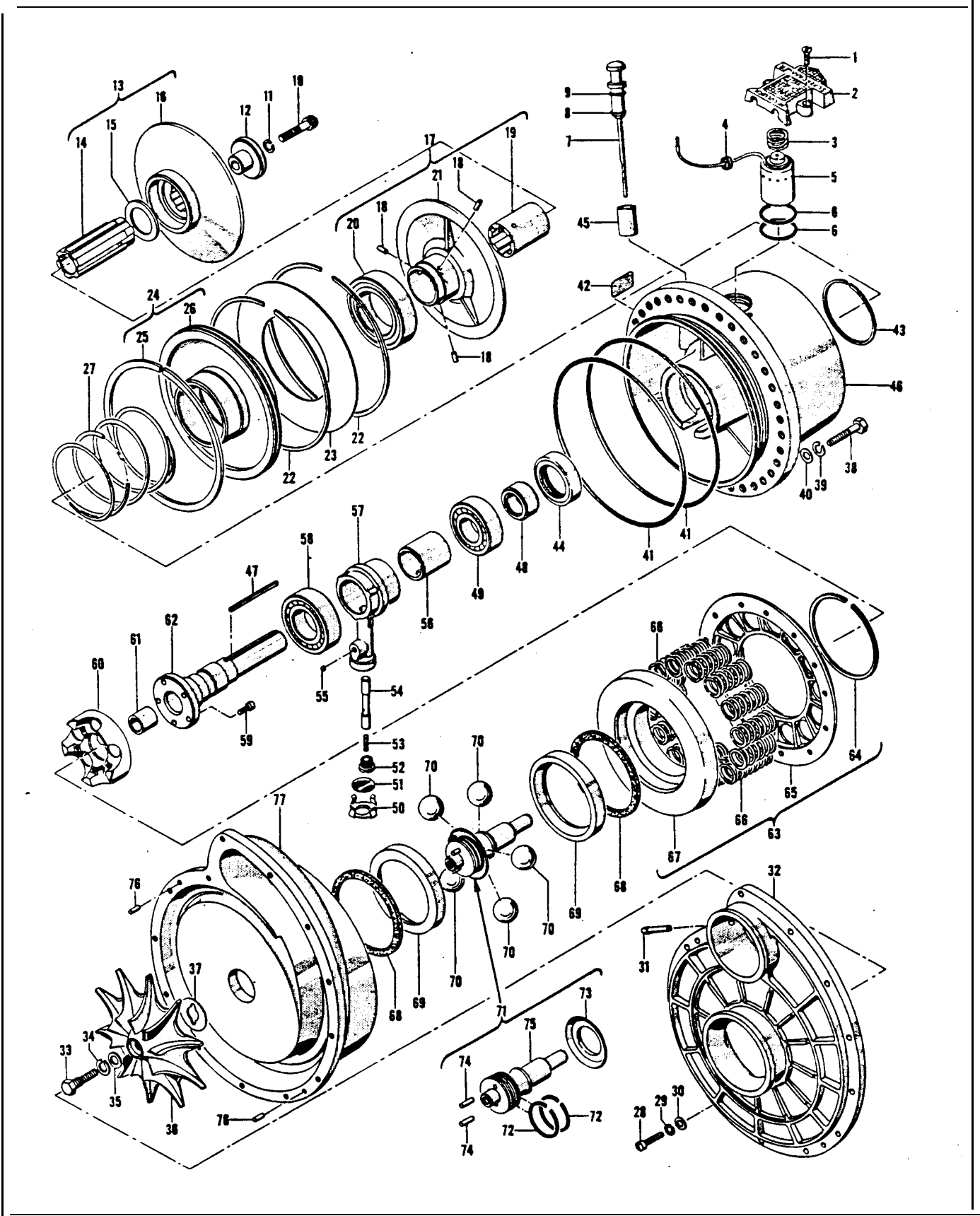

Figure 11

NUMERICAL PARTS - PRICE LIST

McCulloch Supercharger

Model VS-57 Series

February 1955

Part Number	Nomenclature	List Price	Part Number	Nomenclature	List Price
37001A	Scroll • Supercharger	14.50	37081	Ring • Air Cylinder Cover Retaining	.80
37002A	shaft • output	13.40	37082A	Cover • Air Cylinder	.36
37003A	Oil Slinger • Output Shaft	.25	37083	Ring • Air Cylinder (Outer)	1.00
37004A	Race Load Assembly	9.50	37084	Ring • Air Cylinder (Inner)	.85
37006	Bushing • Gil Pump	.30	37085C	Housing • Bearing	25.00
37007B	Plunger • Oil Pump	1.65	37086A	Medallion	.95
37008	Race • Ball	3.00	37087	Spring Air Cylinder Piston	.90
37009	Input shaft	Order 37053	37088	Disc • Ball Race Clutch	.95
37010	Bushing • Input Shaft	.80	37090	Decal	.25
37011	Retainer • Ball	8.70	37094	Sleeve • Seal	1.35
37012	Screw • Input Shaft	.16	37129	Cover Assembly	9.95
37015	Spring	.08	37149	Spring • Solenoid Valve Hold-Down	.25
37018	Shim • Impeller (.026 - .028)	.15	37197	Plug - Oil Pump Body	.25
37018A	Shim • Impeller (.030 - .032)	.15	37203	Retainer • Fixed Driven Pulley	1.05
37018B	Shim • Impeller (.034 - .036)	.15	37264	Washer • Fixed Driven	.20
37018C	Shim • Impeller (.038 - .040)	.15	37283	Gasket • Cover	.10
370180	Shim • Impeller (.042 - .044)	.15	37286	Cover • Scroll Air Hole	.05
370183	Shim • Impeller (.019 - .021)	.15	37309	Body Oil Pump	Order 37055B
37018F	Shim • Impeller (.006 - .007)	.15	37406	Bearing Housing • Service (With Oil	26.05
37019	Retainer • Gil Pump Screen	.15		Gauge Sleeve 4137024 and Decal	
37021	Impeller	7.95		837090 only.)	
37023A	Cover	Order 37129	37442A	Universal Solenoid #4.5 Setting	21.25
37023B	Cover	9.95	37504	Ring and Labyrinth	.35
37024	Sleeve • Gil Level Gauge	.80	37505	Washer and Stop	.05
37025	Gauge • Gil Level	2.00	100003	Washer Plain #10	.01
37026	Screen • Oil Pump	.10	100005	Washer Plain 1/4"	.01
37027	Spring • Oil Gauge Retainer	.15	100246	Lock Washer 1/4"	.01
37050B	Scroll Housing Assembly	14.60	100271	Lock Washer 5/16"	.01
37051B	Output Shaft Assembly	14.75	100350	Washer • Plain .31	.20
37052A	Input & Oil Pump Shaft Assembly	51.05	100436	Lock Washer #10	.01
37053	Input Shaft Assembly	21.80	101254	"O" Ring	1.05
37054B	Oil Pump Assembly	16.50	101948	Screw • Flat Head	.02
37055B	Oil Pump Body Assembly	14.30	102128	Screw Hex Head	.03
37056C	Bearing Housing (Complete with Seal #102430 , Oil Gauge Sleeve #37024 and Inner Ring 837084. See #37406 for service bearing housing.)	26.20	102134	Screw Fl. Head	.02
37061	Cage • Race Load Spring (Front)	2.10	102175	Groov-Pin 1/8" x .50" Type 4	.03
37062	Cage • Race Load Spring (Rear)	2.15	102194	Ball • Drive	.65
37063A	Spring • Race Load	.35	102196	Pin • Dowel	
37064	Snap Ring	.25	102197	Ball Bearing	1 : :
37072A	Piston • Air Cylinder	4.70	102198	Ball Bearing	2.55
37073	Key • Pulley Hub	.10	102199	Screw Hex Head	.06
37074A	Bushing • Splined Driven Pulley	3.05	102224	Screw Fl. Head Machine	Order 102134
37075B	Pulley • Fixed Driven	7.10	102225	"O" Ring • Gil Level Gauge	.20
37076B	Pulley Assembly • Sliding Driven	16.00	102373	Pin	.05
37077A	Pulley • Sliding Driven	6.10	102375	Ball Bearing	3.90
37079C	Fixed Driven Pulley Assembly	16.40	102430	Seal Input Shaft	.75
37080A	Hub • Fixed Driven Pulley	9.10	102436	Hose Connection	.25
			102462	"O" Ring • Solenoid	.18
			102549	Screw Socket Head	.20
			102550	Lock Washer	.01

Paxton Products
827 West Olive Street
Inglewood, California

Prices quoted f. o. b. Los Angeles, California
and subject to change without notice.